

GEARBOX 280, 300 STD

GEARBOX 280, 300 BB

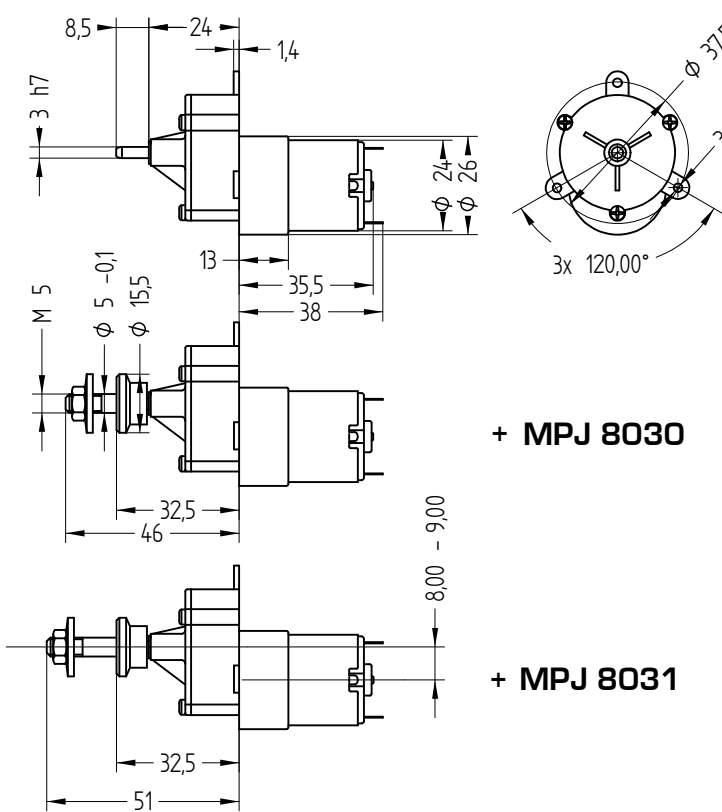

+ MPJ 8030

+ MPJ 8031

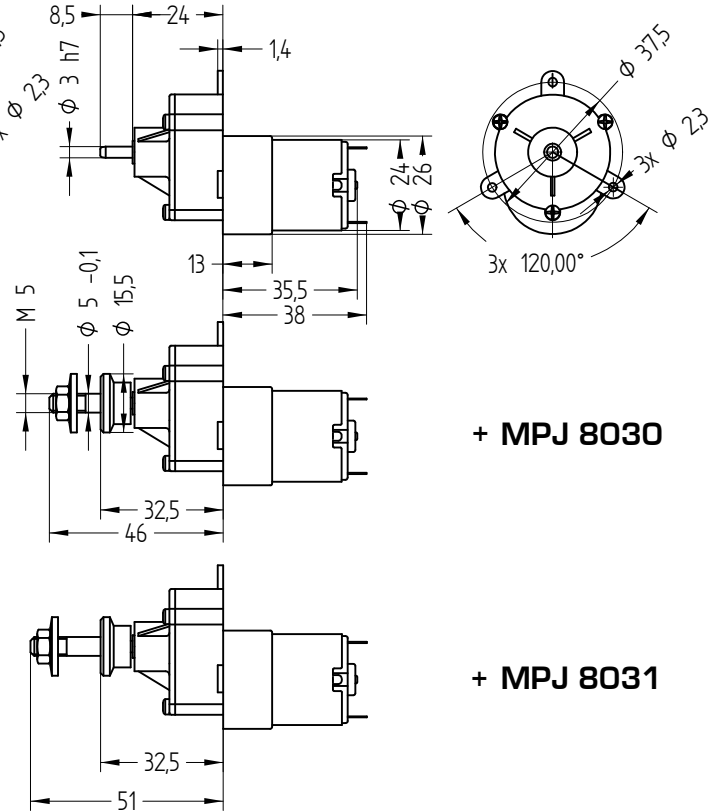

+ MPJ 8030

+ MPJ 8031

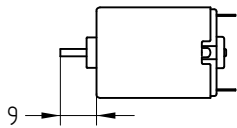

ELECTROMOTOR SHAFT MODIFICATION

MOUNTING ON FIREWALL

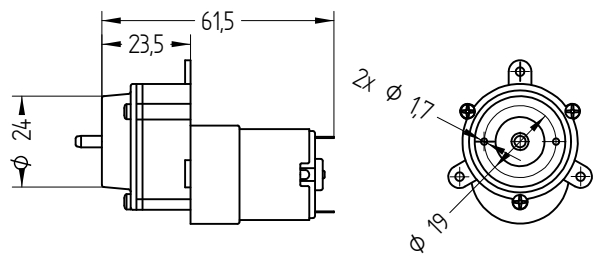

+ MPJ 8035

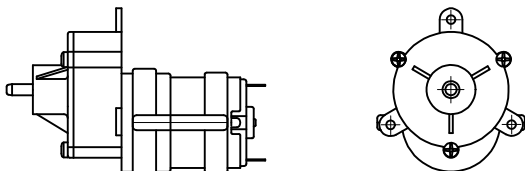
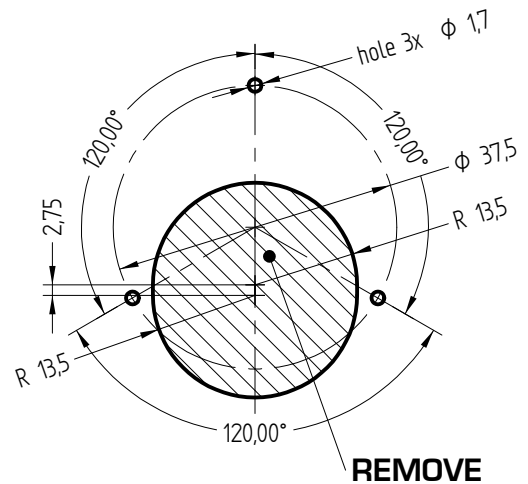

+ MPJ 8036

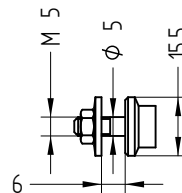

MPJ 8030

recommended for propeller APC

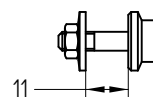
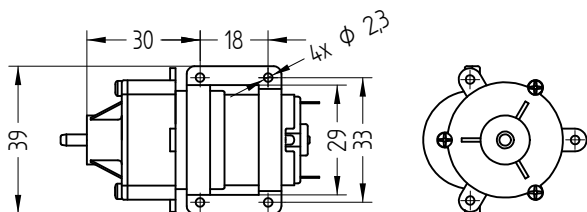

MPJ 8031

recommended for propeller FSK

GEARBOXES FOR ELECTROMOTORS 280 and 300 SIZE

Gearboxes are recommended for model airplanes with weight up to 400g - PARK FLY category. It is designed to be used with MABUCHI 280 (Speed 280), Igarashi 280 (MIG 280) or higher power Sagami 280 BB (Permax 280 BB). The "300" size gearboxes are recommended to be used with electromotor Speed 300. For standard electromotors with plain bearings and ferrite magnets (Speed 280, MIG 280) it is suitable to use gear ratio 4,1:1, three blade propeller FSK, battery pack with seven cells (270 mAh size) and 5A electronic speed control. However, as Permax 280 BB is high RPM type, it is recommended to use gear ratio 4,5:1 or 5:1. It is possible to use the standard three blade propeller FSK or any from of suitable APC, CAM PROP or other. In this case, it is necessary to use 500 mAh battery pack, 8 cells and the electronic speed control has to be 10A size. We recommend gearbox with ball bearings (BB). In any case, it is necessary to adapt the combination electromotor - gear ratio - propeller - electronic speed control - battery pack to your model. Select propeller drivers (MPJ 8030, 8031) based on your type of propeller (MPJ 8030 for APC - narrow hub, MPJ 8031 for FSK - wide hub).

MPJ	8000	Gearbox SF280 5:1, pinion wheel 2 mm dia
MPJ	8001	Gearbox SF280 4,5:1, pinion wheel 2 mm dia
MPJ	8002	Gearbox SF280 4,1:1, pinion wheel 2 mm dia
MPJ	8003	Gearbox SF280 3,75:1, pinion wheel 2 mm dia
MPJ	8004	Gearbox SF280 3,5:1, pinion wheel 2 mm dia
MPJ	8005	Gearbox SF280 BB 5:1, pinion wheel 2 mm dia
MPJ	8006	Gearbox SF280 BB 4,5:1, pinion wheel 2 mm dia
MPJ	8007	Gearbox SF280 BB 4,1:1, pinion wheel 2 mm dia
MPJ	8008	Gearbox SF280 BB 3,75:1, pinion wheel 2 mm dia
MPJ	8009	Gearbox SF280 BB 3,5:1, pinion wheel 2 mm dia
MPJ	8020	Pinion wheel 9 tooth, 2 mm dia, for 5:1
MPJ	8021	Pinion wheel 10 tooth, 2 mm dia, for 4,5:1
MPJ	8022	Pinion wheel 11 tooth, 2 mm dia, for 4,1:1
MPJ	8023	Pinion wheel 12 tooth, 2 mm dia, for 3,75:1

MPJ	8024	Pinion wheel 13 tooth, 2 mm dia, for 3,5:1
MPJ	8035	Front adapter for 280, 300 size
MPJ	8036	Locking tie set for 280 size
MPJ	8041	Gearbox "300" 5:1, pinion wheel 2 mm dia
MPJ	8042	Gearbox "300" 4,5:1, pinion wheel 2 mm dia
MPJ	8043	Gearbox "300" BB 5:1, pinion wheel 2 mm dia
MPJ	8044	Gearbox "300" BB 4,5:1, pinion wheel 2 mm dia
MPJ	8020	Pinion wheel 9 tooth, 2 mm dia, for 5:1
MPJ	8021	Pinion wheel 10 tooth, 2 mm dia, for 4,5:1
MPJ	8030	Collet prop adapter 14,5 mm dia, for 3 mm shaft, M5/22
MPJ	8031	Collet prop adapter 14,5 mm dia, for 3 mm shaft, M5/27
MPJ	8032	Propeller nut small M5
MPJ	8033	Collet 3 mm dia, M5/22 for prop adapters 14,5 mm dia
MPJ	8034	Collet 3 mm dia, M5/27 for prop adapters 14,5 mm dia

MOUNTING TO MODEL

The gearboxes are possible to mount in this three methods:

1. Standard mounting on the firewall with three radial lugs.
2. Like standard electromotor - dismount three PAN HEAD screws 2,2x 6,5, put the front adapter MPJ 8035, use the PAN HEAD screws 2,2x9,5. The complete gearbox with front adapter is mounted like standard electromotor on the firewall in side fuselage.
3. The gearbox is put in place for electromotor from above with locking ties MPJ 8036.

In the front of the fuselage, please make the holes for air ventilation used for cooling of electromotor.

MAINTENANCE

Lubricate the ball bearings with light machine oil, Shell Alvania or Kluber Isoflex LDS 18 grease is recommended for gears. Please do not use the silicone type grease (or with PTFE), as the life of the brass pinion wheel will be very short. Keep the gearboxes clean from the dust.

ASSEMBLING OF PINION WHEEL

The shaft of the motor must be shortened on 9 -0,2 mm (see to drawing on the second side). Use suitable glue (for example Loctite 638 or Weicon LOCK AN 306-38) for glue of pinion wheel on the electromotor shaft.

OTHER TYPES OF MP JET GEARBOXES

FOR ELECTROMOTORS "400" SIZE		
MPJ	8011	Gearbox "400" STD 4,1:1, pinion wheel 2,3 mm dia
MPJ	8012	Gearbox "400" STD 3,5:1, pinion wheel 2,3 mm dia
MPJ	8013	Gearbox "400" STD 3:1, pinion wheel 2,3 mm dia
MPJ	8014	Gearbox "400" STD 2,33:1, pinion wheel 2,3 mm dia
MPJ	8016	Gearbox "400" BB 4,1:1, pinion wheel 2,3 mm dia
MPJ	8017	Gearbox "400" BB 3,5:1, pinion wheel 2,3 mm dia
MPJ	8018	Gearbox "400" BB 3:1, pinion wheel 2,3 mm dia
MPJ	8019	Gearbox "400" BB 2,33:1, pinion wheel 2,3 mm dia
MPJ	8026	Pinion wheel 11 tooth, 2,3 mm dia, for 4,1:1
MPJ	8027	Pinion wheel 13 tooth, 2,3 mm dia, for 3,5:1
MPJ	8028	Pinion wheel 15 tooth, 2,3 mm dia, for 3:1
MPJ	8029	Pinion wheel 18 tooth, 2,3 mm dia, for 2,33:1
MPJ	8037	Front adapter for 400, 480 size
MPJ	8038	Locking tie set for 400 size
FOR ELECTROMOTORS "480" SIZE		
MPJ	8100	Gearbox "480" STD 4,1:1, pinion wheel 3,2 mm dia
MPJ	8101	Gearbox "480" STD 3,5:1, pinion wheel 3,2 mm dia
MPJ	8102	Gearbox "480" STD 3:1, pinion wheel 3,2 mm dia
MPJ	8103	Gearbox "480" STD 2,33:1, pinion wheel 3,2 mm dia
MPJ	8104	Gearbox "480" BB 4,1:1, pinion wheel 3,2 mm dia
MPJ	8105	Gearbox "480" BB 3,5:1, pinion wheel 3,2 mm dia
MPJ	8106	Gearbox "480" BB 3:1, pinion wheel 3,2 mm dia
MPJ	8107	Gearbox "480" BB 2,33:1, pinion wheel 3,2 mm dia

MPJ	8108	Pinion wheel 11 tooth, 3,2 mm dia, for 4,1:1
MPJ	8109	Pinion wheel 13 tooth, 3,2 mm dia, for 3,5:1
MPJ	8110	Pinion wheel 15 tooth, 3,2 mm dia, for 3:1
MPJ	8111	Pinion wheel 18 tooth, 3,2 mm dia, for 2,33:1
MPJ	8037	Front adapter for 400, 480 size
FOR ELECTROMOTORS "500-650" SIZE		
with body diameter 35,5 mm		
MPJ	8120	Gearbox "500-650" BB 2,8:1, pinion wheel 3,2 mm dia
MPJ	8121	Gearbox "500-650" BB 2,33:1, pinion wheel 3,2 mm dia
MPJ	8122	Gearbox "500-650" BB 1,75:1, pinion wheel 3,2 mm dia
MPJ	8123	Pinion wheel 15 tooth, 3,2 mm dia, for 2,8:1
MPJ	8124	Pinion wheel 18 tooth, 3,2 mm dia, for 2,33:1
MPJ	8125	Pinion wheel 24 tooth, 3,2 mm dia, for 1,75:1
MPJ	8126	Front adapter for 500-650 size
MPJ	8127	Locking tie set for 500-650 size
ACCESSORIES FOR GEARBOXES		
MPJ	8030	Collet prop adapter 14,5 mm dia, for 3 mm shaft, M5/22
MPJ	8031	Collet prop adapter 14,5 mm dia, for 3 mm shaft, M5/27
MPJ	8032	Propeller nut small M5
MPJ	8033	Collet 3 mm dia, M5/22 for prop adapters 14,5 mm dia
MPJ	8034	Collet 3 mm dia, M5/27 for prop adapters 14,5 mm dia
MPJ	4703	Collet prop adapter 19 mm dia, for 4 mm shaft, M6/29
MPJ	4683	Collet 4 mm dia, M6/29 for prop adapters 19 mm dia